

Adaptive Relay Selection in Cooperative Wireless Networks

Helmut Adam and Christian Bettstetter

University of Klagenfurt, Mobile Systems Group
Lakeside Park B02a, 9020 Klagenfurt, Austria
Email: [firstname.lastname]@uni-klu.ac.at

Sidi Mohammed Senouci

Orange Labs
2 Avenue Pierre Marzin, 22307 Lannion Cedex, France
Email: sidimohammed.senouci@orange-ftgroup.com

Abstract—The concept of cooperative relaying promises gains in robustness and energy-efficiency in wireless networks. Although protocols for cooperative relay selection were proposed recently, their analysis was made without consideration of the energy required for receiving. Such an analysis is unfair, as relaying requires more receptions than direct source-destination transmission. We consider this lack of analysis and propose two refinements of cooperative relaying. Using “relay selection on demand,” relays are only selected if required by the destination. Using “early retreat,” each potential relay assesses the channel state and decides whether to participate in the relay selection process or not. Simulation results show that these enhancements reduce the overall energy consumption significantly.

Index Terms—Cooperative networking, relay communication, cooperative diversity, selection protocols, energy efficiency.

I. INTRODUCTION

Cooperative relaying is considered to be an untapped means to achieve performance gains in wireless systems, both in the context of relay-enhanced cellular systems and ad hoc networks. The basic building block of this technique is the relay channel: A source node transmits a message to a destination; a third node overhears this transmission and forwards (relays) the message to the destination; finally, the destination combines the two received messages to improve decoding. Such cooperative communication benefits from an inherent spatial diversity of the messages, thus providing a good mitigation against signal fading. The maximum achievable throughput of the relay channel is higher than that of direct source-destination transmission and non-cooperative source-relay-destination relaying (see e.g. [1], [2]). Alternatively, the same throughput is obtained with less energy.

Although some understanding of cooperative relaying has been obtained in the past years, many fundamental questions remain or have just emerged. In particular, only few efforts have been made in analyzing the impact and requirements of cooperative relaying on functions above the physical layer. This observation is the motivation for our research in this area. Key questions of interest include: How to design protocols that determine suitable relays out of a set of candidate relays? How to make such relay selection protocols resource-efficient, yet enabling a high diversity gain?

First steps to address these issues are made in [3], presenting a basic protocol for relay selection and assessing its performance (see Section II). Protocol enhancements were made in

[4] with the goal to minimize the message complexity of the selection process. The paper at hand builds upon that work and extends it with focus on strategies to save energy. Scanning the literature, we observe that the analysis of cooperative relaying is often made without consideration of the energy required for *receiving* (see e.g. [5]–[8]). Such analysis is unfair, as relaying requires more receptions than direct transmission. We consider this lack of analysis and propose two refinements of cooperative relaying (Section III): (i) a *relay selection on demand* scheme in which relays are only determined if really needed by the destination and (ii) an *early retreat* scheme in which nodes with bad channel conditions do not participate in the relay selection. We show by simulation that both enhancements improve the energy efficiency, while the degradation in terms of outage rate compared to [3] depends on a configurable parameter and is negligible for the target packet error rate. Related work is addressed in Section IV.

II. BASIC RELAY SELECTION

The task of relay selection is as follows. A source S wants to send a message to a destination D . There are several adjacent nodes between S and D , which are candidates to become a cooperative relay node. Relay selection determines the node that is “best suited” to act as a relay R . The selection process should operate in a distributed manner and introduce only a reasonable overhead in terms of message complexity and delay.

In relay-enhanced cellular systems, relay selection determines a relay that helps in the communication between a mobile device and a base station. In ad hoc networks, relay selection operates below the routing protocol, selecting an additional relay between two nodes in a multihop path. In both cases, the protocol should not rely on topology information.

To perform these tasks, a *relay selection protocol* can be introduced, which exchanges signaling messages between S and D to determine a good relay before the actual payload message is sent; the selected relay then receives and forwards the payload message. Such a protocol is proposed in [3]. Assuming a slow fading environment, it determines the relay node R that offers the lowest overall end-to-end outage probability for each message to be sent.

The selection process can be achieved in four steps (see Fig. 1): In the first two steps, each potential relay estimates

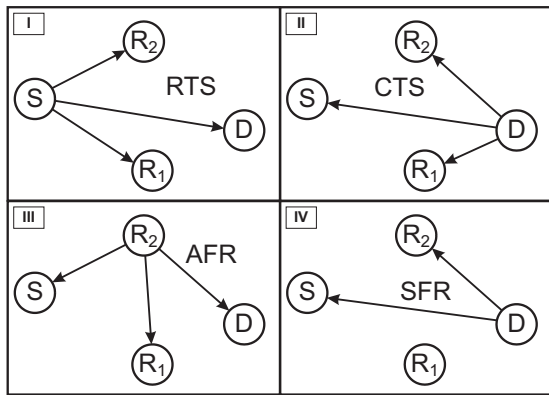

Fig. 1. Signaling messages for relay selection

the instantaneous channel quality between itself and S as well as itself and D , respectively. This can be accomplished as follows: Node S sends a `ready-to-send` (RTS) message, which is received by D and all other neighbors of S . Upon reception of the RTS, node D sends back a `clear-to-send` (CTS) message. Both messages are pilot signals; they contain no further information and are transmitted with the same carrier frequency and the same power used for the payload data transmission later on. By receiving the RTS message, a potential relay R_i can determine the channel state information (CSI) h_{SR_i} from S to R_i . Equivalently, from the CTS message, it determines the CSI h_{DR_i} from D . Assuming that the forward and backward channels between R and D are the same, we have $h_{R_iD} = h_{DR_i}$ due to the reciprocity theorem.

The CSI values h_{SR_i} and h_{R_iD} are combined in some manner, yielding the overall suitability of a node to act as a relay. This suitability is denoted by $h_i = f(h_{SR_i}, h_{R_iD})$. Determining the function f yielding the “best” relay is not straightforward, but it was shown in [3] that a simple max-min policy yields good performance: Each node determines the worse of both CSI values, i.e., $h_i = \min\{h_{SR_i}, h_{R_iD}\}$, then the node with best worst CSI value should serve as a relay. This strategy outperforms, for example, a policy based on the harmonic mean of the CSI values [3], the reason for this being the fact that if one of the CSI values is bad, relaying is impossible, no matter how good the other CSI is.

The remaining problem is how to efficiently communicate the fact that a node has won the selection process. Each R_i sets a timer to a value τ_i that is inversely proportional to the overall suitability h_i of the node. The timer of the best-suited node (highest h_i) expires first. Upon expiration of the timer, this node sends an `apply-for-relay` (AFR) message. The destination acknowledges with a `select-for-relay` (SFR) message. Both messages inform all potential relays about the fact that a node has won the selection process; hence, all nodes stop their own timer. Furthermore, S is informed about the relay node and can start transmission of the payload data. Note that D must also implement a timer to avoid deadlocks in case of missing relays.

If D can decode the message sent by S correctly, it sends an

Acknowledgment (ACK) back to S which is also overheard by the selected relay. If D cannot decode the source message, no ACK is sent, and a timer in R expires. If R can decode the source message correctly, it forwards it to D . Since relaying is only performed if requested by D , this scheme can be called *on-demand relaying*. If the relay cannot decode the message, a timer in S expires and the scheme starts from the beginning. This acknowledgment concept is similar to Hybrid Automatic Repeat Request (HARQ).

It was shown in [9] that this basic protocol is able to outperform more complicated schemes with multiple relays. It is applicable if the entire time period required for relay selection, direct transmission, and relayed transmission is expected to be smaller than the coherence time of the channel. The achieved diversity order is equal to the number of nodes which receive both messages RTS and CTS [3]. As the protocol exploits the wireless channel at its best, it is also considered to be an *opportunistic* relaying protocol [3].

The message complexity of the selection protocol is given in Table I. We distinguish between the number of transmission (TX) and reception (RX) operations. Nodes detecting both RTS and CTS are potential relays. The number of these nodes is called m . The number of nodes detecting the RTS message from the source [the CTS message from the destination] is denoted by m_S with $m_S \geq m$ [m_D with $m_D \geq m$]. The column named “waiting” represents the time period during which all participating nodes wait for the best relay to report.

TABLE I
MESSAGE COMPLEXITY OF THE BASIC RELAY SELECTION PROTOCOL

mode	RTS	CTS	waiting	AFR	SFR
TX	1	1	–	1	1
RX	$m_S + 1$	$m_D + 1$	$m + 2$	$m + 1$	2

III. ENHANCED RELAY SELECTION

Most proposals for cooperative relaying ignore the energy required for receiving but consider only the transmission energy (see e.g. [5]–[8]). In real-world radios, however, the energy consumed for receiving is of the same magnitude as the one needed for transmission. For instance, a typical IEEE 802.11 interface card operating at 4.74 V consumes 284 mA in transmit mode and 190 mA in receive mode as well as 156 mA in idle mode; it consumes however only 10 mA in sleep mode. It is thus a desired design criterion in energy-efficient wireless communications to maximize periods in sleep mode [10]. Given this, we further improve the basic relay selection scheme.

A. Modeling Assumptions and Performance Criteria

A signal $x(t)$ is transmitted over the channel. It experiences attenuation described by a fading coefficient h as well as additive white noise. The signal received at a time instant t is $y(t) = h \cdot x(t) + n(t)$. Assuming quasi-static flat fading, the fading coefficient h is constant during one communication cycle, i.e., during the entire period from relay selec-

tion, over direct source-destination transmission, until relay-destination transmission. For each cycle, a coefficient h is chosen randomly from a Rayleigh distribution with parameter $\sigma = \sqrt{L/2}$, where L is the path loss of the observed link. The noise n is a Gaussian variable with zero mean and variance $N_0/2$, the term N_0 being the spectral noise density. Further modeling assumptions are:

- Radios cannot transmit and receive at the same time.
- Different transmissions are done in orthogonal channels.
- CSI is not exploited or not known at the physical layer.
- No channel coding is used.
- Coherent antipodal modulation is used (e.g., BPSK).
- Relays perform decode-and-forward [6].
- Corrupted packets are not merged at D .

To obtain a fair comparison of the three schemes (direct transmission, basic cooperative relaying, and enhanced cooperative relaying), the overall transmission energy used for payload data is for all schemes the same. In case of cooperative relaying, the transmission energy is divided into two equal parts between S and the selected relay.

As major performance criterion, we use the average *energy consumption* per successfully delivered packet,

$$\bar{E}_P = \bar{b}_{tx} \cdot E_{tx} + \bar{b}_{rx} \cdot E_{rx} + \bar{t}_{waiting} \cdot P_{idle}. \quad (1)$$

The term \bar{b}_{tx} [\bar{b}_{rx}] represents the average number of transmitted [received] bits per correctly delivered packet; both values also include the overhead required for relay selection. The term $\bar{t}_{waiting}$ corresponds to the average contention time per packet of all nodes. E_{tx} and E_{rx} are the energy values needed for transmitting or receiving, respectively, and P_{idle} is the power consumption in idle mode. These values are derived from measurements in [11] with $P_{mode} = U \cdot I_{mode}$, with constant voltage U and a current I_{mode} that depends on the used transceiver mode (TX, RX, idle, sleep). For a data rate of r bits per second, the energy per bit for transmission or reception is $E_{mode} = P_{mode}/r$. To obtain a fair comparison, we assume that the current I_{mode} used in cooperative relaying schemes is half of the current used in direct transmission.

Another performance criterion is the *outage rate* of a packet transmission. We define it as the probability that a destination node cannot decode a sent message correctly. For direct S - D transmission, this definition is identical to the packet error rate (PER). For cooperation, an outage occurs if the S - D link fails, while the S - R link or/and the R - D link fails. For a given energy per sent bit E_b and a given bandwidth, the outage rate is a function of the instantaneous CSI.

B. Relay Selection On Demand

1) *Motivation*: Cooperative relaying is used to mitigate the effects of small scale fading. Whenever the direct S - D channel is in a deep fading period with a high PER, an attempt is made to overcome this situation with help of a relay R . With increasing channel quality, however, the PER from S to D decreases, hence the importance of the relaying task diminishes. Energy can be saved by *skipping* relay selection whenever D does not need any cooperation.

2) *Description*: We introduce a channel-adaptive scheme in which relays are only selected when relaying is needed with high probability. This scheme is called *Relay Selection on Demand (RSoD)*. The basic idea is that the destination decides whether a relay should be determined or not. As above, S starts by sending an RTS message. From this transmission, D derives the instantaneous CSI to S and thus can estimate the expected PER. We use an application-dependent threshold Θ to assess the relevance of cooperation ($\Theta \in [0, 1]$). If the expected PER is below this threshold, D responds with an SFR message, all relay candidates power down their radio, and S starts transmitting its payload data. If the PER is above Θ , the scheme behaves like the basic relay selection protocol to trigger cooperative relaying. In summary, cooperation is used if the current channel provides a higher PER than Θ .

3) *Probability of Cooperation*: Let us now calculate the probability of cooperation $P_c = \Pr[\text{PER} > \Theta]$. The bit error rate of a BPSK transmission is [12]

$$\text{BER} = \frac{1}{2} \text{erfc}(\sqrt{\text{SNR}}), \quad (2)$$

with $\text{SNR} = \frac{h^2 E_b}{N_0}$. The PER of uncoded data is

$$\text{PER} = 1 - (1 - \text{BER})^n, \quad (3)$$

with n being the number of bits in the packet. This yields

$$\begin{aligned} P_c &= \Pr \left[h^2 < \frac{(\text{erfc}^{-1}(2 \cdot (1 - \sqrt{1 - \Theta})))^2}{E_b/N_0} \right] \\ &= 1 - \exp \left(- \frac{(\text{erfc}^{-1}(2 \cdot (1 - \sqrt{1 - \Theta})))^2}{L \cdot E_b/N_0} \right). \end{aligned} \quad (4)$$

4) *Performance Evaluation*: Simulations are made with a self-developed C++ tool. For a given E_b/N_0 the tool simulates message transmission initiated by a source S addressed to a destination D in a scenario where S , potential relays, and D have equal distances and are in transmission range of each other. The equal distance setting eliminates any hop gains. The size of data packets is $n = 1024$ bits, signaling messages (RTS, CTS, AFR, SFR) are 24 bits large, and the data rate is $r = 19.200$ bit/s. If an outage occurs, the packet will be retransmitted by S . The confidence of the depicted results is 95% within the interval of $\pm 1\%$. The used thresholds yield meaningful results of our simulations, which have been conducted on various chosen values.

Fig. 2 compares the outage rates of direct transmission, cooperative relaying with basic relay selection (RSbasic), and cooperative relaying with RSoD as a function of the received SNR. For RSoD, various packet-error thresholds are employed.

For low SNR, there is no gain using cooperative relaying, but direct S - D transmission is favorable. This is because only half of the transmission power is used in the relaying case. With increasing SNR (above 8 dB), relaying benefits from the diversity gain and outperforms direct transmission.

The threshold Θ influences the cooperation behavior of RSoD. For very high Θ , no diversity gain can be achieved, thus the outage rate is always worse than that of direct transmission.

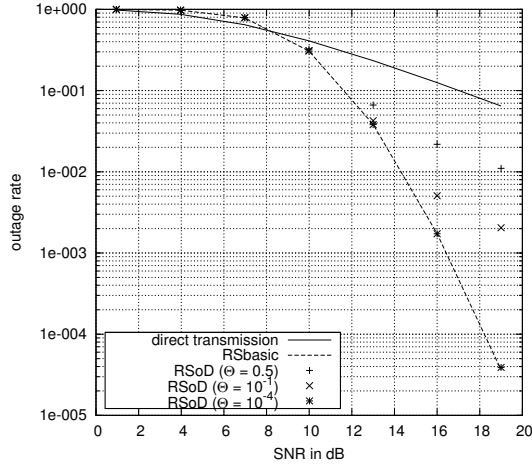

Fig. 2. Relay selection on demand (RSoD): Outage rate

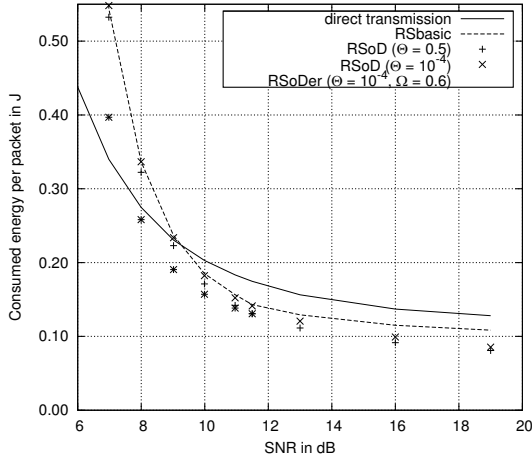

Fig. 3. RSoD and RSoDer (see Section III-D): Energy Consumption

For adequately chosen Θ , the outage rate of RSoD is, up to the target PER, identical to the one of RSbasic. Above this bound, the curve becomes parallel to the outage curve of direct transmission, since cooperation is hardly used.

The number of skipped relay selections depends on Θ and the received SNR. As SNR increases, fewer relays are selected due to the low PER from S to D . If relay selection is skipped, the signaling overhead is reduced (see Table II), the contention period is avoided, and no relay has to overhear the S - D transmission. Fig. 3 depicts the average energy consumption per successfully delivered packet for $\Theta_1 = 0.5$ and $\Theta_2 = 10^{-4}$. Beyond 10 dB SNR cooperation achieves better results with respect to outage rate and energy consumption. Comparing Fig. 2 and 3 it can be seen that, although there is a significant difference in outage rate, the deviation on consumed energy is minimal for different Θ s and is always less than the RSbasic consumption (compare at 19 dB).

In summary, the RSoD extension saves energy in the high SNR regime and behaves like RSbasic in the low SNR regime.

TABLE II
SIGNALLING OVERHEAD WHEN COOPERATION IS NOT NEEDED

mode	RTS	CTS	waiting	AFR	SFR
TX	1	0	-	0	1
RX	$m_s + 1$	0	0	0	$m_d + 1$

C. Relay Selection with Early Retreat

1) *Motivation*: The second enhancement modifies the behavior of the relay candidates. In RSbasic all nodes which receive the RTS and CTS messages enter the competition phase of the selection process regardless of the measured CSIs. To further minimize the energy consumption, we propose that each potential relay decides, based on the measured CSIs, whether it participates in this competition or not. We call this modification *Relay Selection with Early Retreat (RSer)*.

2) *Description*: All nodes receiving an RTS message from S or/and a CTS message from D estimate the expected PERs. If at least one of the PERs exceeds a given threshold Ω , a node retreats, i.e., it does not participate in the further selection process. Finally, only nodes with a good channel to both S and D set a timer to compete for becoming a relay. A node retreating after reception of the RTS does not need to receive the CTS and does not have to wait for the best node to report with an AFR. If it retreats after the CTS reception it avoids the waiting period and the reception of the AFR.

3) *Early Retreat Probability*: The probability that a node is not able to serve as relay and thus retreats from the relay selection competition is $P_{ER} = 1 - (1 - \Pr[\text{PER} > \Omega])^2$. The probability $\Pr[\text{PER} > \Omega]$ is given by (4).

4) *Performance Evaluation*: Fig. 4 illustrates the outage probability of the RSer scheme with different Ω and compares it to direct transmission and RSbasic. The number of nodes competing for the relay task is proportional to Ω — the higher Ω the more nodes compete. If Ω is chosen in such a way

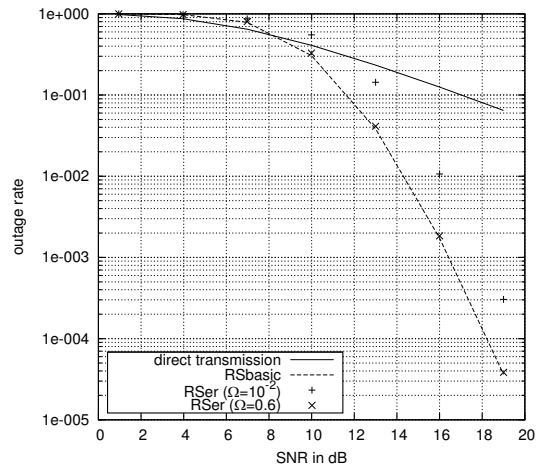

Fig. 4. Relay selection with early retreat (RSer): Outage rate

that retreating nodes cannot forward the payload data without errors, energy is saved and the outage rate does not degrade as compared to RSbasic. If Ω is very low, also nodes which

could support the direct S - D transmission retreat; the resulting outage behavior is then a right-shifted copy of RSoDer.

D. Relay Selection on Demand with Early Retreat

It is straightforward to combine RSoD and RSer into one scheme, which we call *Relay Selection on Demand with Early Retreat (RSoDer)*. Figs. 3, 5 and 6 show its performance using the thresholds $\Theta = 10^{-4}$ and $\Omega = 0.6$, these values being chosen due to their performance in the above simulations.

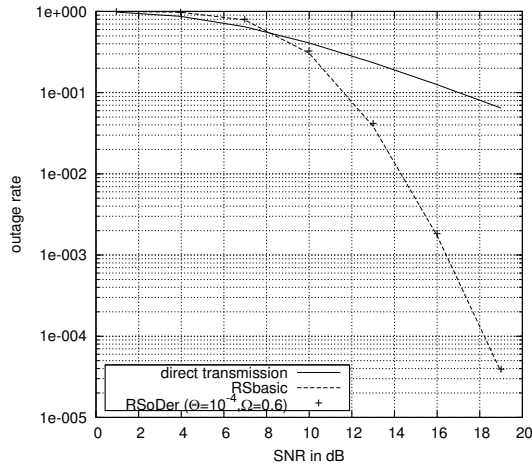

Fig. 5. Relay selection on demand with early retreat: Outage rate

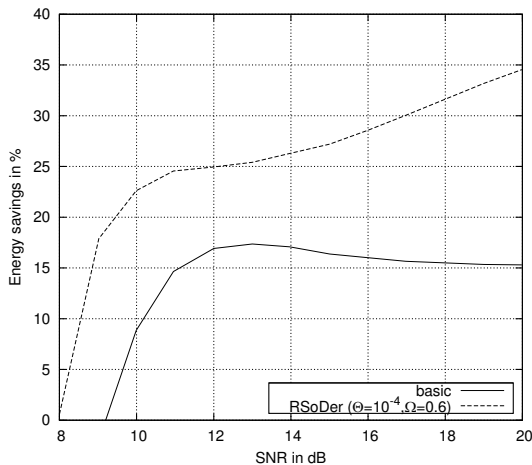

Fig. 6. Relay selection on demand with early retreat: Energy savings

For an SNR above 8 dB, both relaying schemes show gains with respect to outage rate and energy consumption, compared to direct transmission. Comparing RSoDer and RSoDer, we observe that RSoDer has almost the same outage rate but always requires less energy.

For medium SNR, the energy gain is due to fewer re-transmissions of failed packet transmissions. With increasing SNR, energy savings are achieved more and more from the reduced transmission energy of the two cooperative schemes. For RSoDer, the overhead caused by cooperation, i.e. relay

selection and overhearing S - D transmission, does not pay off and mitigates some of the savings. RSoDer however avoids unnecessary cooperation attempts and thus uses less energy.

IV. RELATED WORK

Hwang *et al.* [4] introduce an optimization of [3], trying to minimize the number of RTS and CTS messages. The approach chooses the first node as relay whose instantaneous CSI of both links is above a predefined threshold. It always selects a relay regardless of the quality of the S - D channel.

Chen *et al.* [13] propose a relaying scheme with power control, which chooses a relay that minimizes the required energy for a desired data rate.

Chou *et al.* [14] combine relay selection and medium access. Cooperation is only used whenever the direct link does not support a desired data rate. However, potential relays determine the necessity of cooperation and not the destination. Analysis focuses on the outage rate and the timing.

V. CONCLUSIONS

This paper studied relay selection with explicit consideration of the energy required to receive data. In this context, we introduced a *relay selection on demand with early retreat* protocol. Simulation results indicate that this protocol brings good benefits with respect to energy efficiency, compared to state-of-the-art cooperative relaying protocols, while showing almost no performance loss in terms of outage rate.

REFERENCES

- [1] R. U. Nabar, H. Bölcskei, and F. W. Kneubühler, "Fading relay channels: Performance limits and space-time signal design," *IEEE J. Select. Areas Commun.*, vol. 22, no. 6, pp. 1099–1109, Aug. 2004.
- [2] A. Høst-Madsen and J. Zhang, "Capacity bounds and power allocation for wireless relay channels," *IEEE Trans. Inform. Theory*, vol. 51, no. 6, pp. 2020–2040, June 2005.
- [3] A. Bletsas, A. Khisti, D. F. Reed, and A. Lippman, "A simple cooperative diversity method based on network path selection," *IEEE J. Select. Areas Commun.*, vol. 24, no. 3, pp. 659–672, Mar. 2006.
- [4] K.-S. Hwang and Y.-C. Ko, "An efficient relay selection algorithm for cooperative networks," in *Proc. IEEE VTC*, Baltimore, MD, Sept. 2007.
- [5] H. Dubois-Ferriere, D. Estrin, and M. Vetterli, "Packet combining in sensor networks," in *Proc. ACM SenSys*, San Diego, CA, Nov. 2005.
- [6] J. N. Laneman, D. N. C. Tse, and G. W. Wornell, "Cooperative diversity in wireless networks: Efficient protocols and outage behavior," *IEEE Trans. Inform. Theory*, vol. 50, no. 12, pp. 3062–3080, Dec. 2004.
- [7] T. E. Hunter and A. Nosratinia, "Diversity through coded cooperation," *IEEE Trans. Wireless Commun.*, vol. 5, no. 2, pp. 283–289, Feb. 2006.
- [8] N. Shastry, J. Bhatia, and R. S. Adve, "A theoretical analysis of cooperation diversity in wireless sensor networks," in *Proc. IEEE Globecom*, St. Louis, MO, Nov. 2005.
- [9] A. Bletsas, H. Shin, and M. Win, "Outage-optimal cooperative communications with regenerative relays," in *Proc. Ann. Conf. Information Sciences and Systems*, Princeton, NJ, March 2006.
- [10] I. Kurtis Kredon and P. Mohapatra, "Medium access control in wireless sensor networks," *Comput. Networks*, vol. 51, no. 4, pp. 961–994, 2007.
- [11] L. Feeney and M. Nilsson, "Investigating the energy consumption of a wireless network interface in an ad hoc networking environment," in *Proc. IEEE INFOCOM*, Anchorage, AK, April 2001.
- [12] K.-D. Kammeyer, *Nachrichtenübertragung*, 3rd ed. Teubner, 2004.
- [13] Y. Chen, G. Yu, P. Qiu, and Z. Zhang, "Power-aware cooperative relay selection strategies in wireless ad hoc networks," in *Proc. IEEE PIMRC*, Helsinki, Finland, Sept. 2006.
- [14] C.-T. Chou, J. Yang, and D. Wang, "Cooperative mac protocol with automatic relay selection in distributed wireless networks," in *Proc. Pervasive Computing and Communications Workshops*, White Plains, NY, March 2007.